



Made by Alutech, specified by you.

SL160 – Lift and Slide Doors

- Maximum vision - Minimal sight lines - 110mm
- Maximum security - PAS 24 approved
- Maximum insulation value - Down to 1.0 U W/m²K
- Maximum sash width - 3235mm
- Maximum sash height - 3385mm
- Single or dual colour to any RAL colour

SL160

Alutech Systems is one of the largest designers and manufacturers of Aluminium Systems in the world.

We pride ourselves on providing outstanding design and specification to make our products stand out from other manufacturers.

The SL160 Lift and Slide Door can be used in both Residential and Commercial applications. Designed to meet the highest thermal standards and the largest openings, the door is robust and reliable during any application.

Specification at a glance

- Maximum weight of 440kg per door leaf - providing for the largest openings
- Panels up to 3385mm high and 3235mm wide, without having to upgrade rolling hardware
- Possible 1.0 U W/m2k value – when using Hi-insulation frame
- Air, wind and water tested
- Engineering grade running rollers for a smooth and quiet opening and closing operation
- Simple fabrication
- PAS 24 Security rated
- Glazed frame or dummy sash option available
- Double and triple track option available

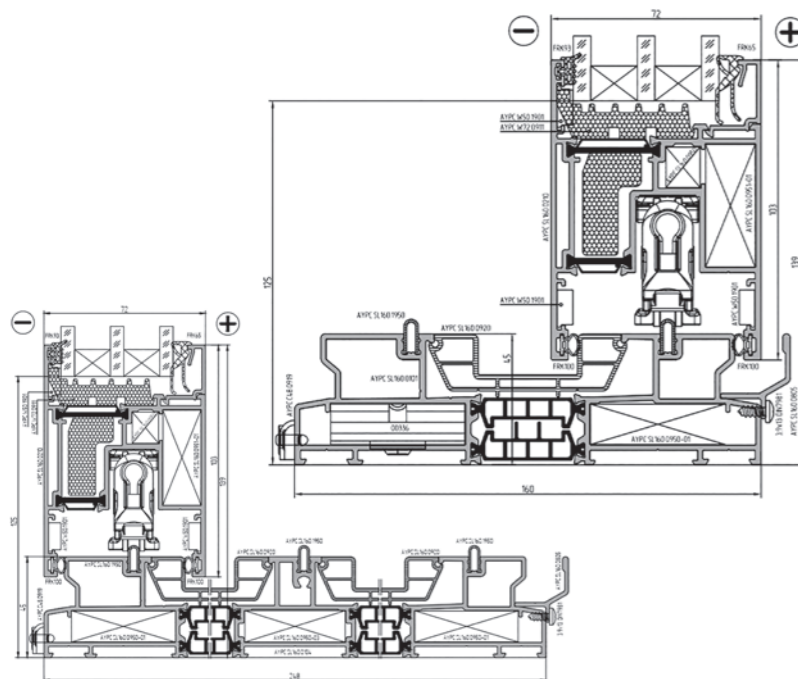

Inline Sliding Doors



Bi-folding door



Residential Windows

Technical detail

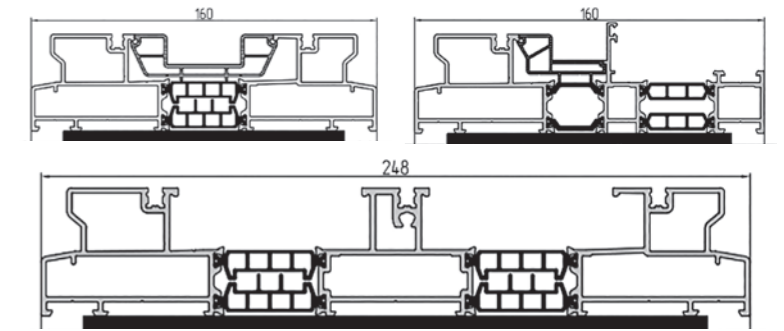

Table of dimensions

Fixed areas	Dummy sash and 'glaze in' frame options available
Frame depth	160mm
Central interlock	110mm
Glass possibilities	26mm, 28mm, 30mm, 32mm, 34mm, 36mm, 38mm, 40mm, 42mm, 44mm, 46mm, 48mm, 50mm Double & triple glazed unit
Max sash height	3385mm
Max sash width	3235mm
Max frame height	3400mm
Max frame width*	6500mm

SL160 options

Finish

Single or dual colour. Factory powder coated to marine quality as defined by Qualicote regulations.

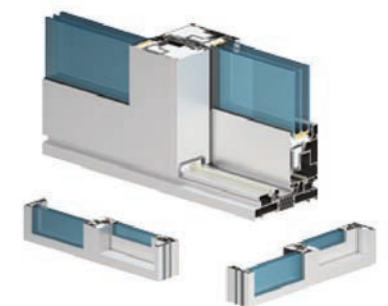

Hardware

Handles are available in black finish, stops are finished in black or white as standard.

Threshold

Threshold can either be placed on the inside or the outside of the building

Security

PAS (24:2016) Tested

Span*

Coupling profile available for doors over 6.5m

Sliding configurations



Other products manufactured by the Alutech Group

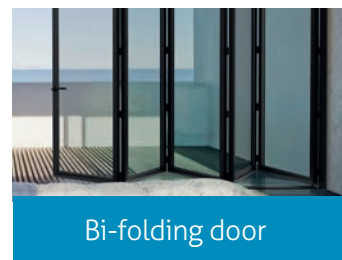
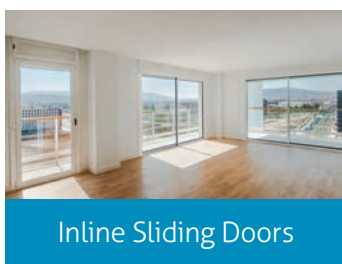

For more information contact Alutech Systems Ltd.

Alutech Systems Ltd

Low Mill Lane, Havelock Street, Ravensthorpe Industrial Estate, Ravensthorpe, Dewsbury, WF13 3LN United Kingdom

E-mail: info@alutechsystems.co.uk **Call us:** 01924 350 110